



**DOR-O-MATIC**®

---

# Series ICU Door Trackless

Installation Instructions  
and Service Manual

## **DOR - O - MATIC**®

7350 W. Wilson Ave.  
Harwood Heights, IL 60706

Toll Free: 1-800-543-4635  
In Illinois: 708-867-7400  
Sales FAX: 708-867-0291  
Engineering FAX 708-867-1177  
[www.doromatic.com](http://www.doromatic.com)

<b>INDEX</b>
--------------

<b>TITLE</b>	<b>PAGE</b>
<b>INSPECTION</b>	<b>3</b>
<b>FRAME MOUNTING</b>	<b>4</b>
<b>PANEL (SO) INSTALLATION</b>	<b>6</b>
<b>DOOR (SX) INSTALLATION</b>	<b>8</b>
<b>BUMPER BAR INSTALLATION</b>	<b>10</b>
<b>GLAZING</b>	<b>11</b>
<b>RELEASE FOR SERVICE</b>	<b>12</b>

## INSPECTION

1. Verify that the order was shipped complete and correct, including model number, color, and package width and height.
2. Verify at **job site** that **all conditions** are correct and in accordance with **final approved shop drawings**.
  - A. Check that the opening is the correct size. Correct size is package width plus  $\frac{1}{2}$ " (13mm) and package height plus  $\frac{1}{4}$ " (6mm), for shimming and caulking (**Figure 1**).

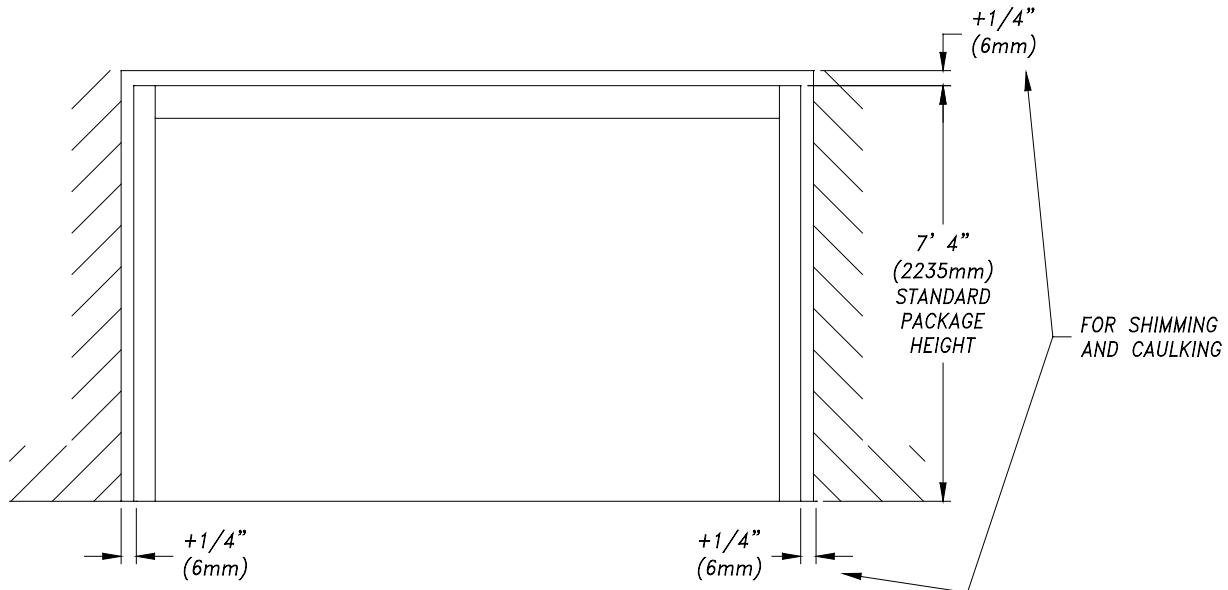

**FIGURE 1: Clearance Required at Rough Opening**

- B. Check that the floor is level. Use a minimum 6'-0" (1829mm) level **or** use the actual aluminum header turned upside down to check floor (**Figure 2**).
- C. Using a plumb bob, check that the rough opening where the jambs will be mounted is vertical (**Figure 2**).
- D. Check the diagonal measurements to insure that the opening is a true rectangle, not just a parallelogram (**Figure 2**).

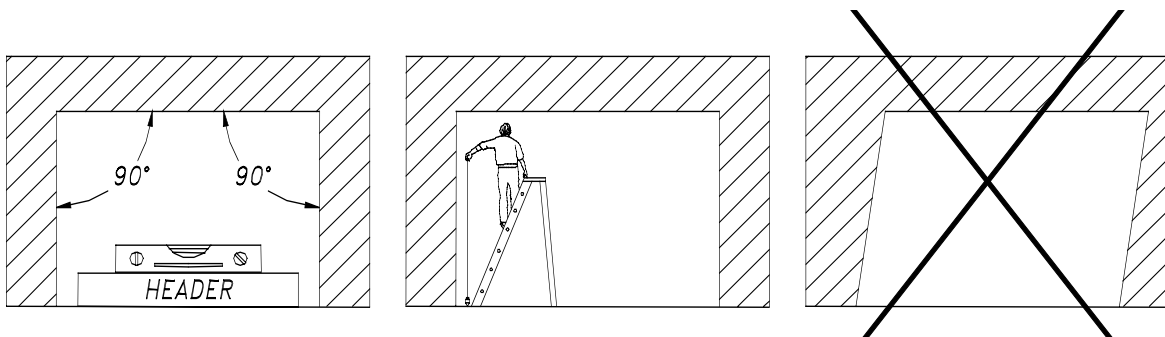
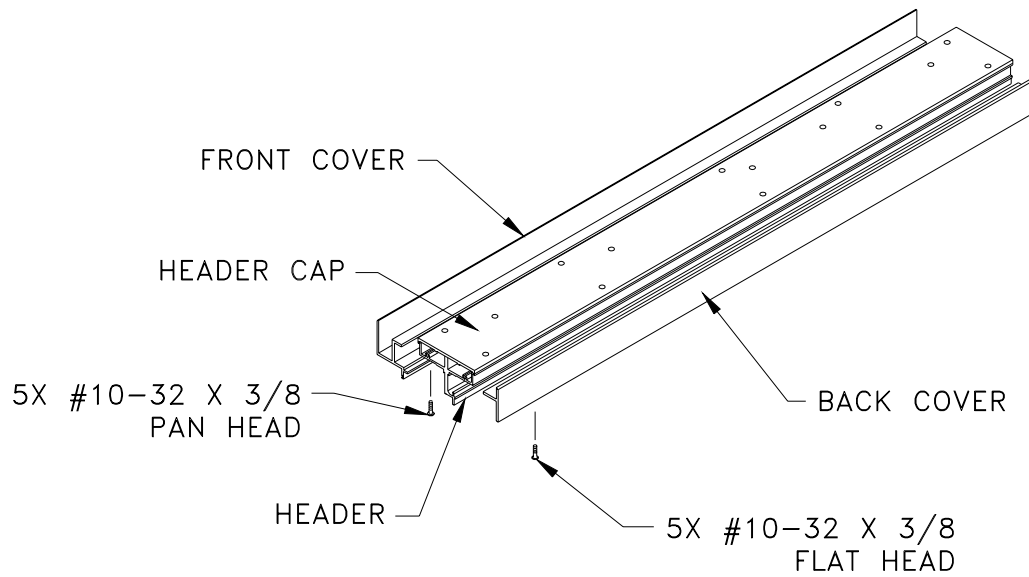

**FIGURE 2: Check Rough Opening**

**NOTE:** If any of the above items are not correct, **do not attempt to install the Series ICU package!** Report any incorrect items to the general contractor **immediately**. Do not proceed until all conditions are correct.

## FRAME MOUNTING

1. Open the carton marked "HEADER". Remove the header and set on a piece of cardboard. Remove front and back covers (do not remove header cap). (Figure 3).



**FIGURE 3: Cover Removal**

2. Verify opening height; remove excess material as necessary from bottom of jambs.
3. Align the jamb tubes with the ends of the header, making sure that the bolt holes lineup with mounting grooves in the header. Use two #10-24 X 1" screws (found in blister pack) on each side to secure the header to jambs. (Figure 4).

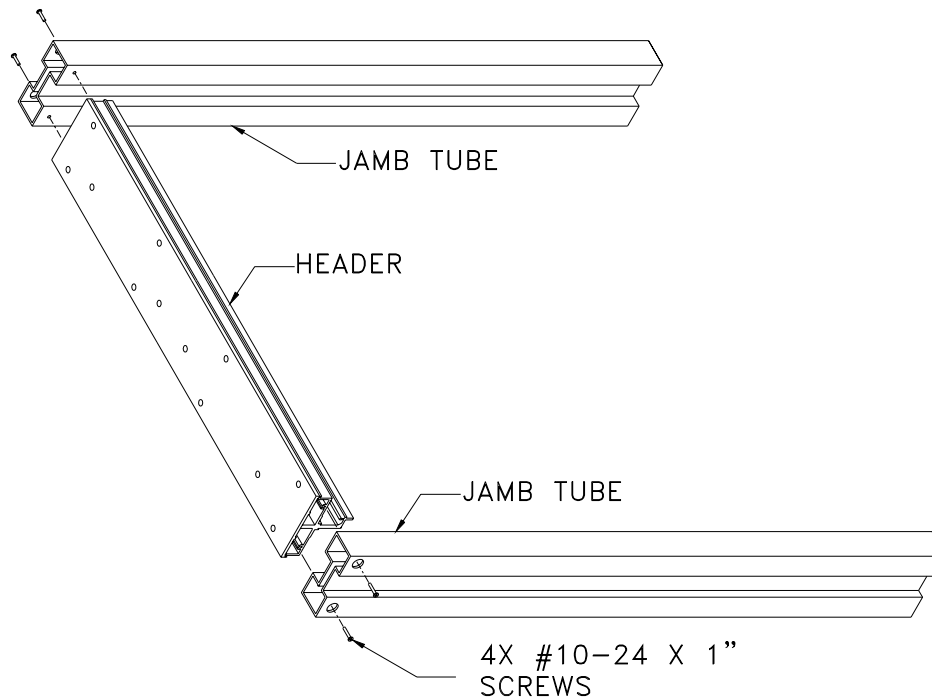

**FIGURE 4: Jamb Tube Attachment to Header.**

4. Tip up the jamb/header assembly and position it within the rough opening. Verify that the package is located correctly within the rough opening – refer to the final approved shop drawings. The Series ICU package is **usually** centered within the opening or is mounted flush with the curtain wall, but verify the position with the drawings, contractor, architect, etc.
5. Insert shims around unit allowing 1/4" (6mm) gap on each side.
6. Use appropriate fasteners (four per jamb) to anchor through the glazing recess of the jamb tube to the wall or adjacent framing. Check the jamb tubes with a level to be sure that the tubes have not been pulled in by the anchors. Finally, install the snap-in glazing strips into the jamb tubes (**Figure 5**).

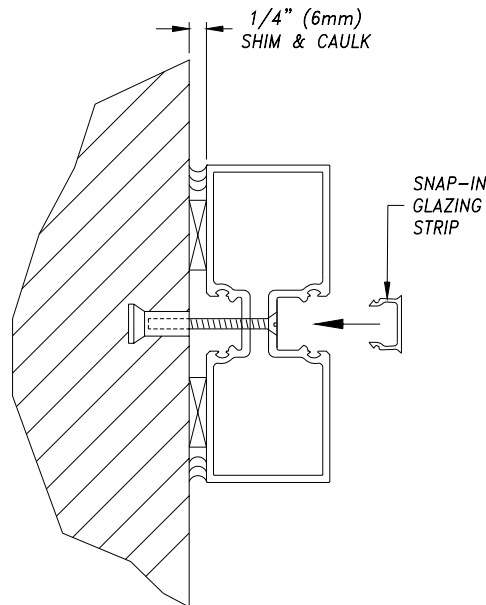

**FIGURE 5:** Anchoring the Jamb Tube

7. Install pivot base plate (found in blister pack). Keeping plate edge flush with edge of jamb tube, use it as a guide drill through holes into floor material for mounting anchors (**Figure 6**).
8. Insert plastic anchors into floor and screw threshold down.
9. Thread the panel pivot post (found in blister pack) into the pivot base plate and adjust to correct height.

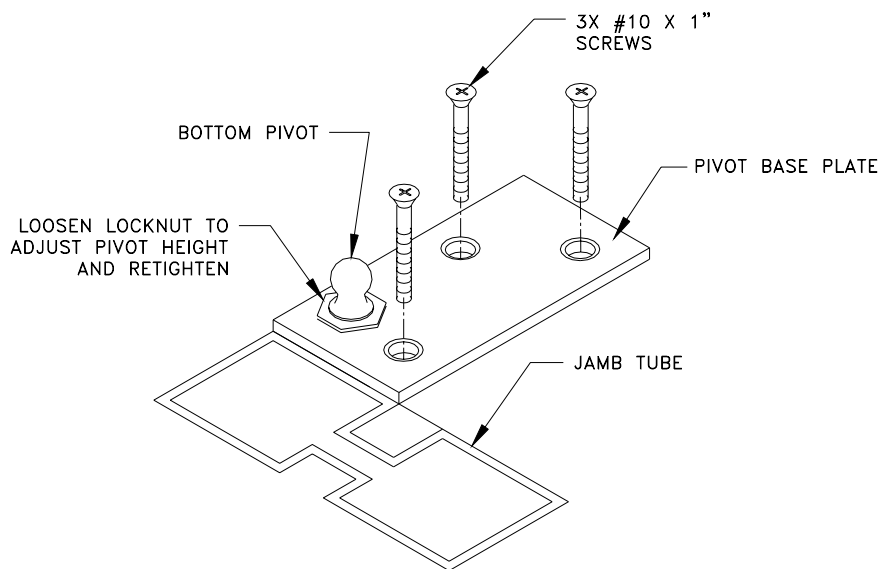
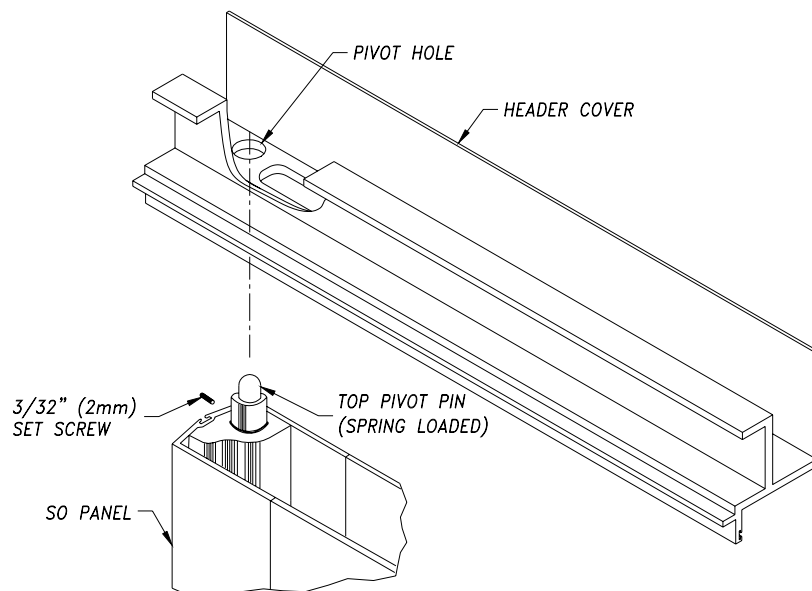
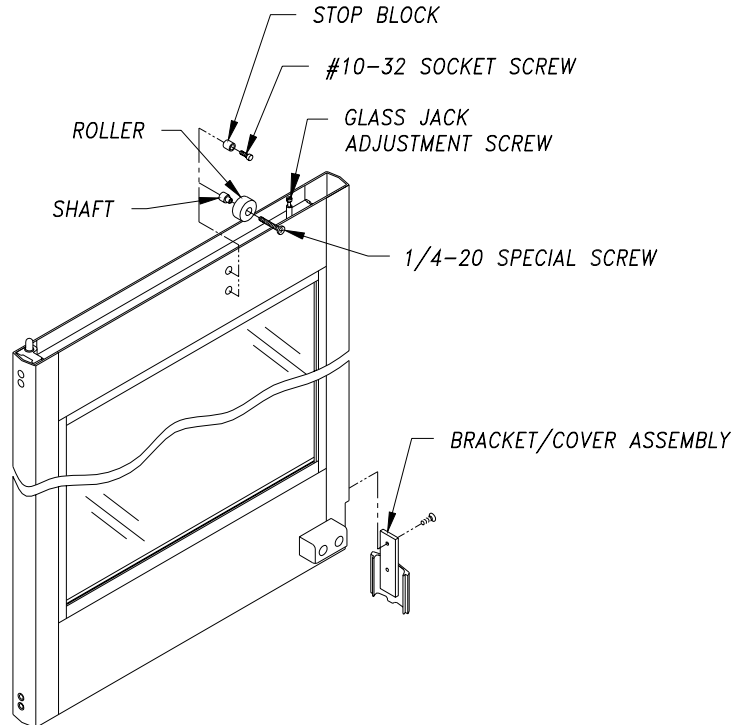

**FIGURE 6:** Installation of pivot base plate.

## PANEL (SO) INSTALLATION

1. Remove panels from carton. Install roller and stop block (found in blister pack) to the top rail.
2. Remove bracket/cover assembly prior to panel installation (**Figure 7**) and close the opening after door has been installed.

**FIGURE 7: Panel Detail**



**FIGURE 8: Panel Top Pivot Detail**

- Top pivot pin is shipped in retracted position. Loosen set screw and release top pivot pin. Lift panel and place bottom pivot block (factory prepped and installed in bottom panel stile) onto bottom pivot. Depress top pivot pin and swing panel into place so pivot pin locks into receiver (pivot) hole. (**Figures 8 and 9**).

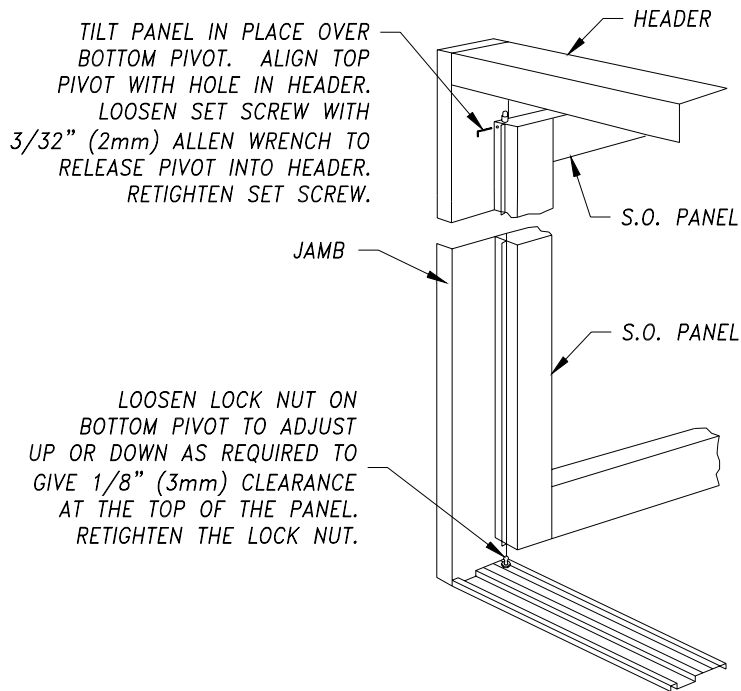

- Adjust bottom pivot post to give the required 1/8" (3mm) clearance at the top of the panel (**Figure 9**).

**FIGURE 9: Panel Installation Detail**

- Slowly close the panel after securing the pivots into position. The clearance between the top of the panel and the bottom of the header should be less or equal to 1/8" (3mm) To correct the clearance, remove the panel and adjust the height.
- In order to remove panel, loosen set screw and push pin down with finger. (**Figure 10**).

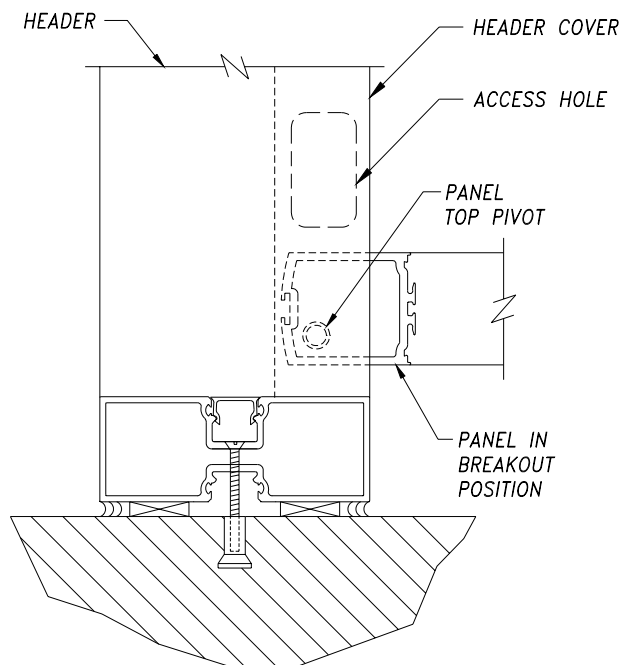

**FIGURE 10: Panel Removal Detail**

## DOOR (SX) INSTALLATION

1. Remove the doors from the carton. Install floating pivot assembly (found in blister pack) into the door bottom rail using two screws attached to the pivot assembly. (Figure 11).

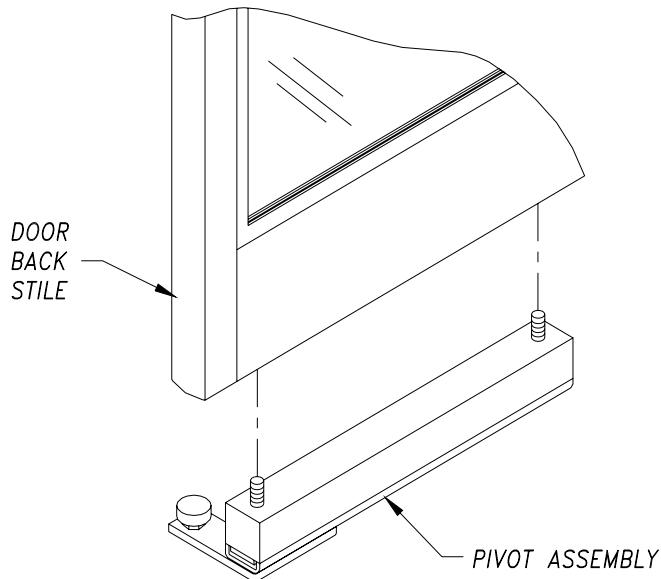

**FIGURE 11: Installation of Door (SX) Bottom Pivot Assembly.**

2. Remove carrier wheel assemblies from blister pack. Remove the #5/16-18 x 1" screw and washer from each wheel assembly. Install carrier wheel assemblies first on header track in position as shown (Figure 12).

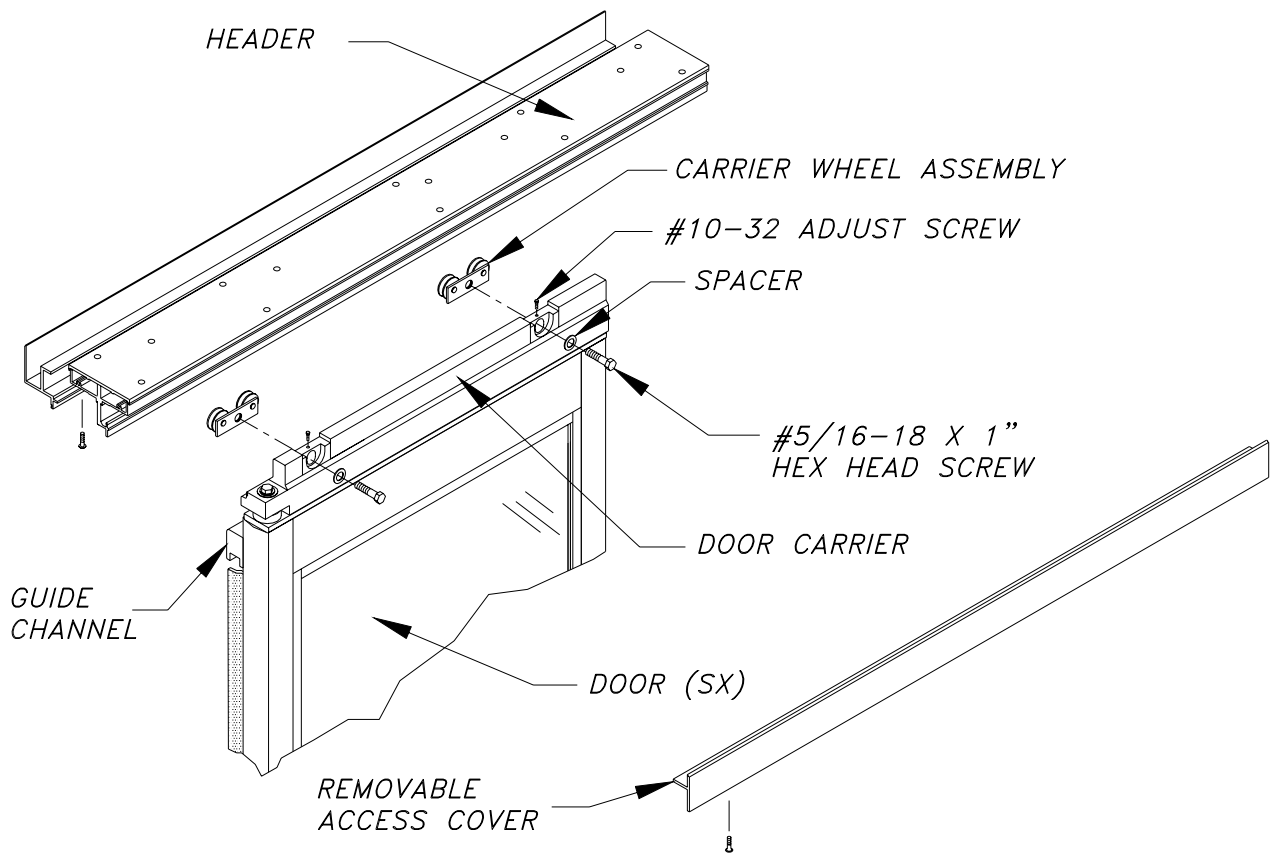

**FIGURE 12: Door (SX) Attachment Height And Adjustment Procedure**

3. Hang the door assembly on carrier wheel assemblies using #5/16-18 hex head screws and spacers. **(Figure 12).**
4. To adjust door height, keep the 5/16-16 screw loose and turn #10-32 adjust screw (clockwise to lower the door). To keep the door level, be sure to adjust both carrier wheel assemblies on each door. After finding the correct level height, secure the assembly in place by tightening 5/16-18 screws. **(Figure 12).**

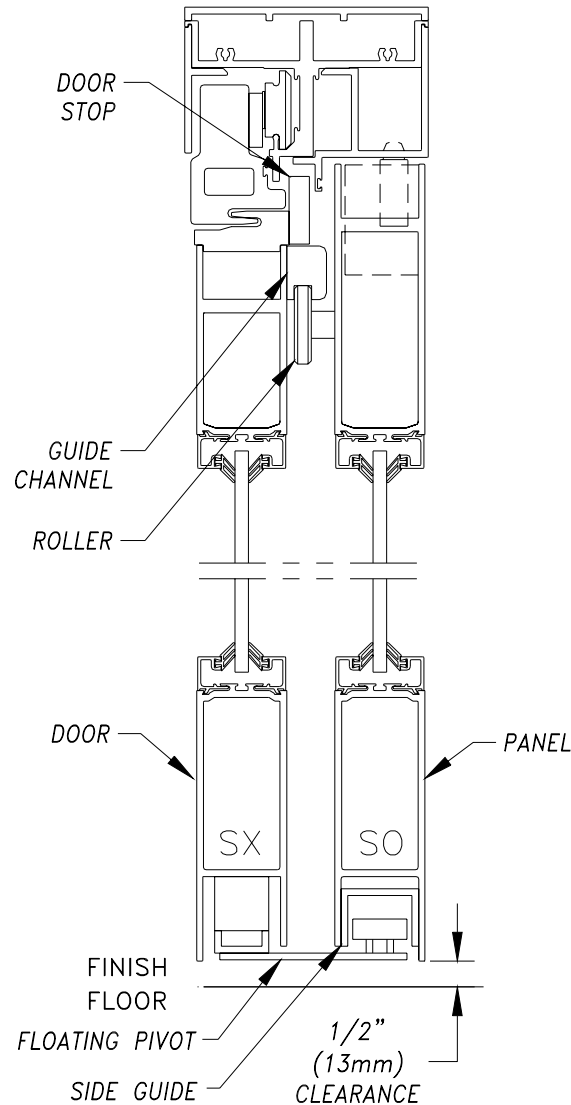
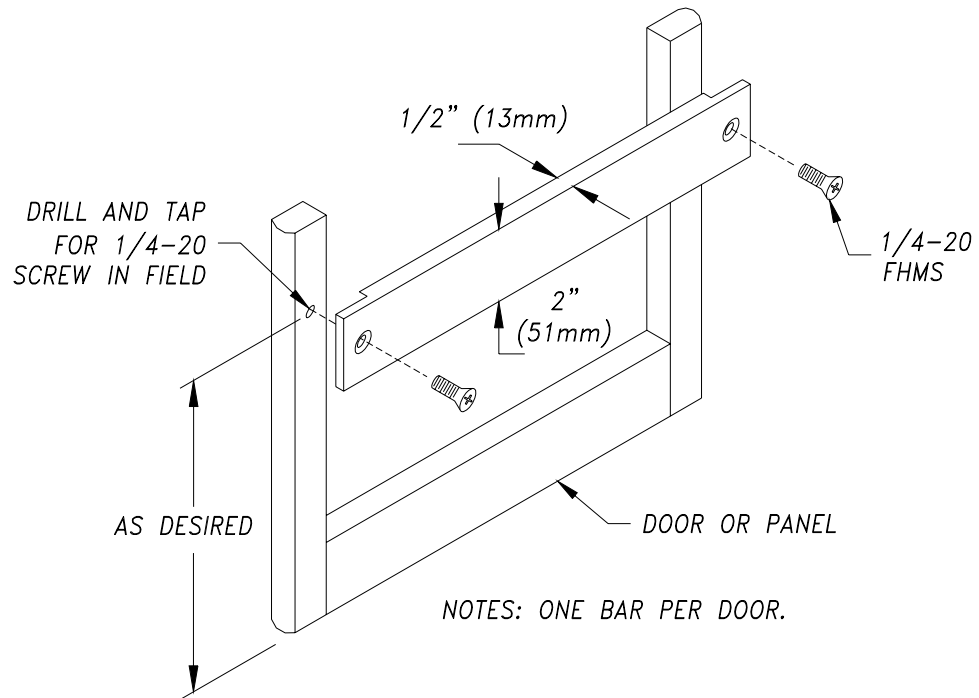

**FIGURE 13: Section view.**

5. Slide door forward the panel and insert floating pivot wheel into bottom panel rail thru the opening. At the same time put top guide channel on panel roller. Close panel bottom nose window with cover **(Figures 7 and 13).**
6. Verify that the bottom pivot is in the bottom rail channel and top channel supports by panel roller Slowly slide the door back and forth to assure smooth operation

## BUMPER BAR INSTALLATION

Refer to the following illustration for Dor-O-Matic bumper bar installation (**Figure 14**).



**FIGURE 14: Bumper Bar Installation**

## GLAZING

1. Refer to the following chart for maximum weight of door and glass as well as maximum glass thickness.

Door/Panel	Max. Weight of Door & Glass	Glass Thickness
SX Door	150 lbs. (68kg.)	1/4" (6mm)
SO Swing Out Panel	200 lbs. (90 kg.)	1/4" (6mm)

**NOTE:** The average weight of a 42" (1067mm) door or panel less glass is 40 lbs. (18 kg.).

- A. Tempered or laminated glass is required in doors and panels per ANSI Z97.1-1972.
- B. If the installation is a "standard package", the glass sizes (both with 2" (51mm) muntins and without) are called out in the Dor-O-Matic details and specifications book, along with the model number of the package.
- C. If the installation is **not** a standard package, measure the width and height between the stile extrusions and **subtract 1/2" (13mm) (Figure 21)**. This is the glass size to order.

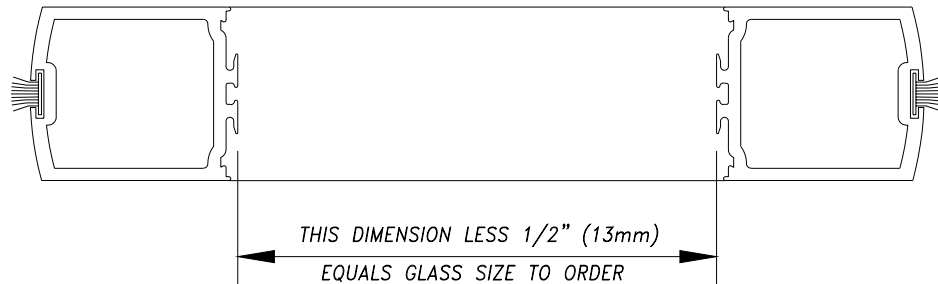

**FIGURE 21: Glass Measurement**

2. A feature unique to Dor-O-Matic is our "Security Glazing System". When glazing the doors and panels, snap in two horizontal and two vertical **exterior** glazing stops. Be sure the stops are securely snapped into the rails and stiles. Place the bottom of the glass onto the nylon glazing blocks and tilt up into vertical position. Have a helper hold the glass in place, and proceed to snap-in the **interior** glazing stops. This design makes the glass non-removable from the exterior. Run a pocketknife or small scraper around the perimeter of the glass to correct rubber that is punched or tucked against the glass.

**IMPORTANT:** After glass has been installed adjust height of bottom panel nose using glass jack adjustment screw (**Figure 7**), to prevent floor scrubbing.

**RELEASE FOR SERVICE**

Clean the glass. Install all safety, traffic control, and instruction decals to the door as required. **This is very important! Failure to do this leaves the installer LIABLE for any accident that might occur. This must be done!** Demonstrate the unit; review all safety features as well as the safety check that is to be performed by the owner each morning.